



Помпа потопяема дренажна за фекални и отпадни води City Pumps TITAN 20/50 PM



RANGE OF PERFORMANCE

Flow rate up to 1200 l/min (72 m³/h)
Head up to 16 m

LIMITS OF USE

Depth up to 10 m
Liquid temperature up to + 40°C
Passage of solid bodies max Ø 50 mm for TITAN 15-20-30/50 P
Passage of solid bodies max Ø 70 mm for TITAN 15-20-30/70 P
For continuous duty: minimum immersion 430 mm from pump base

INSTALLATION AND USE

TITAN P SERIES PUMPS ARE MADE OF EXCEPTIONALLY ROBUST HEAVY GAUGE CAST IRON, RESISTANT TO ABRASION AND LONG LASTING, AND HAVE A VORTEX TYPE IMPELLER. THEY ARE SUITABLE FOR SEWAGE, WASTE WATER AND SLUDGE, INCLUDING WATER CONTAINING SOLIDS OR MUD. THEY ARE IDEAL FOR FIXED SEWAGE INSTALLATIONS, TUNNELS, UNDERGROUND CARPARKS, SUMPS AND SIMILAR APPLICATIONS.

GUARANTEE 2 YEARS subject to our general terms of sale.

CONSTRUCTION CHARACTERISTICS

- PUMP BODY, MOTOR CASING AND BASE PED-ESTAL: cast iron.
- IMPELLER: vortex in cast iron.
- BASE: stainless steel AISI 304.

• MOTOR SHAFT:

stainless steel EN 10088-3 - 1.4057.

• DOUBLE SEAL:

mechanical seal silicon carbide - widia - NBR, with oil barrier chamber and inner lip seal to protect the seal in the event of dry running.

• MOTOR:

submersible asynchronous, 2 pole, for continuous duty.
TITAN P M: single-phase 220÷240 V - 50 Hz
Models up to 1.5 kW have built in thermal protection. 2.2 kW single-phase versions have a thermal protector provided in the winding for connection to the control box.

TITAN P: three-phase 380÷415 V - 50 Hz. Thermal protectors are provided in the winding for connection to the external control panel

• INSULATION: class F.

• PROTECTION: IP 68.

STANDARD FEATURES:

- Base pedestal elbow (duct foot)
- Threaded delivery counterflange
- Top supports for guide tubes

TITAN P M (single-phase)

- Float switch.
- 10m "H07 RN-F" submersible power cable with Schuko plug.
- 1.1 to 1.5 kW models are supplied with control box with capacitor and manual reset motor protector. 2.2 kW models are supplied with control box type QES 300 MONO.

TITAN P (three-phase)

- 10m "H07 RN-F" neoprene power cable

OPTIONS ON REQUEST

- ⇒ control box for three-phase pumps
- ⇒ dual voltage: 230/400 V or 400/690 V
- ⇒ single-phase versions without float switch
- ⇒ other voltages or frequency 60 Hz

CONSTRUCTION AND SAFETY STANDARDS

EN 60034-1

IEC 34-1

CEI 2-3



DIMENSIONS

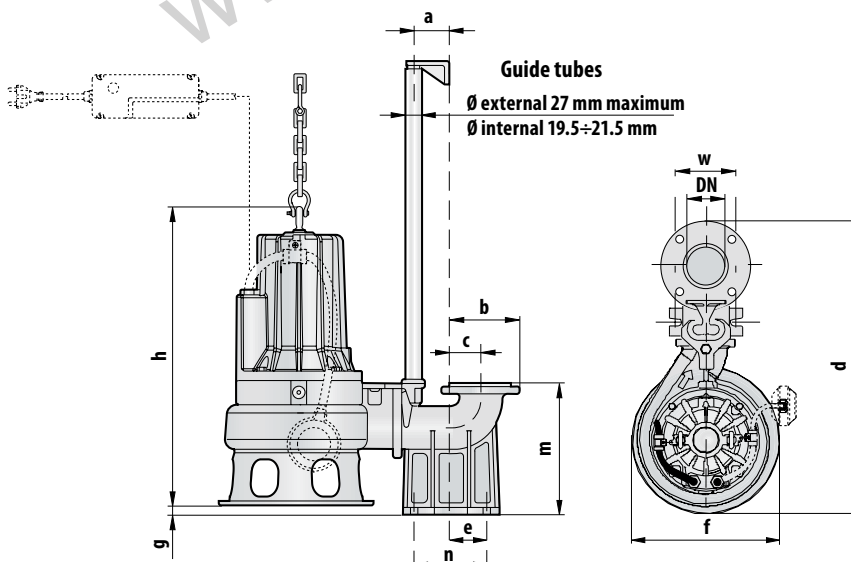

Typical installation

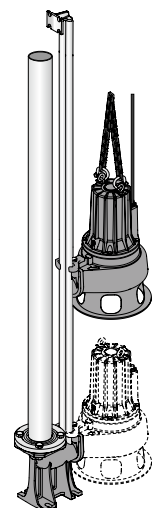



stationary version
TITAN P
VORTEX submersible pumps

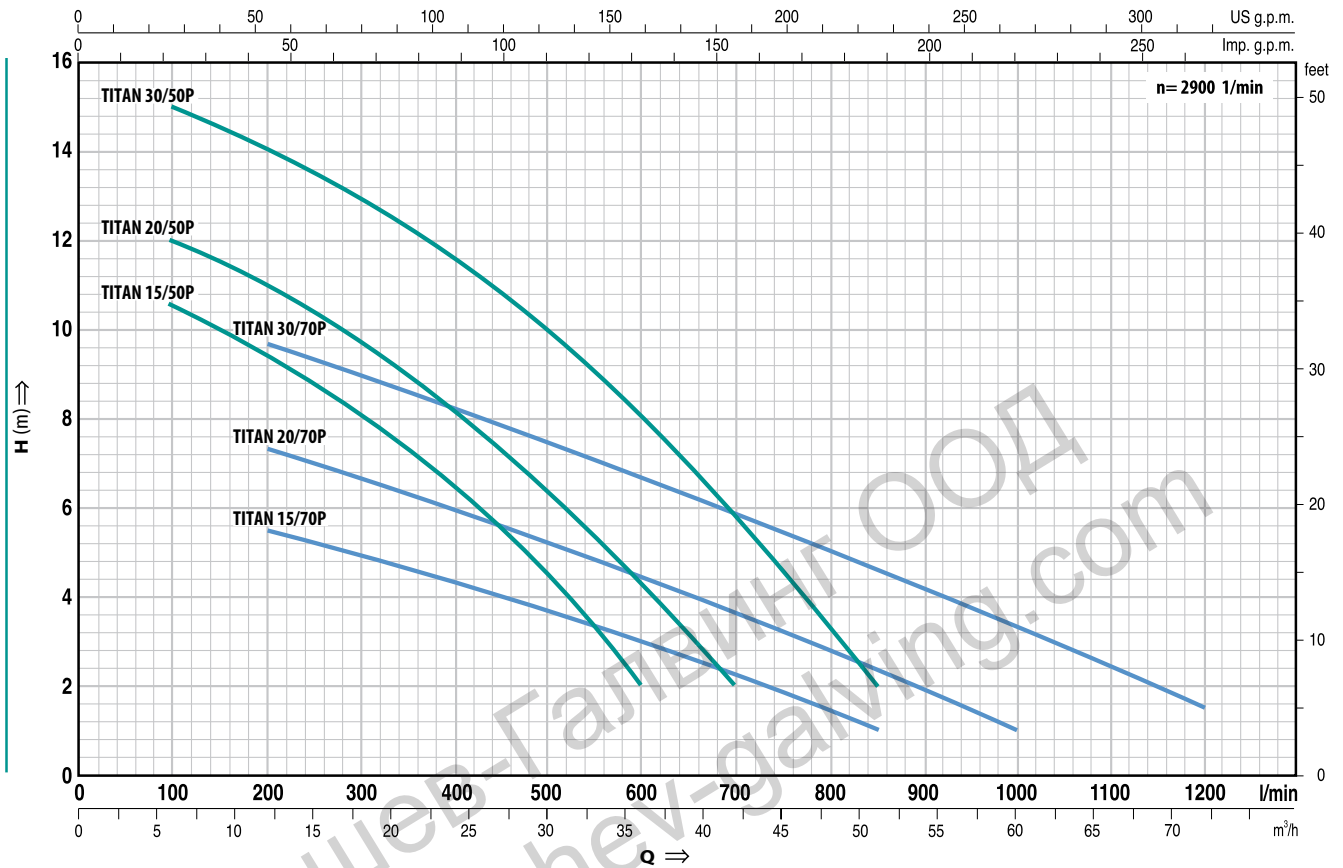

Q = Flow rate H = Total manometric head

Tolerance of the performance curves according to EN ISO 9906 App. A.

TYPE		POWER		m³/h l/min	H metres																
Single-phase	Three-phase	kW	HP		0	6	12	18	21	24	27	30	36	42	48	51	54	60	66	72	
				0	100	200	300	350	400	450	500	600	700	800	850	900	1000	1100	1200		
TITAN 15/50PM	TITAN 15/50P	1.1	1.5	11.5	10.5	9.5	8.2	7.2	6.5	5.6	4.5	2									
TITAN 20/50PM	TITAN 20/50P	1.5	2	13	12	11	9.5	9	8	7.2	6.5	4.5	2								
TITAN 30/50PM	TITAN 30/50P	2.2	3	16	15	14	13	12.3	11.5	10.8	10	8	5.9	3.3	2						
TITAN 15/70PM	TITAN 15/70P	1.1	1.5	6.5	---	5.5	5	4.7	4.4	4	3.7	3	2.2	1.5	1						
TITAN 20/70PM	TITAN 20/70P	1.5	2	8.5	---	7.4	6.7	6.3	6	5.6	5.2	4.5	3.6	2.8	2.4	2	1				
TITAN 30/70PM	TITAN 30/70P	2.2	3	11	---	9.7	9	8.6	8.2	7.8	7.5	6.7	5.8	5	4.6	4.2	3.3	2.5	1.5		

DIMENSIONS AND WEIGHTS

TYPE		PORT DN	passage of solid bodies	DIMENSIONS mm											kg*	
Single-phase	Three-phase			a	b	c	d	e	f	g	h	m	n	w	1~	3~
TITAN 15/50PM	TITAN 15/50P	2 1/2"	Ø 50 mm	60	116	51	501	62	270	10	387	200	120	72	42.0	40.0
TITAN 20/50PM	TITAN 20/50P														43.8	42.3
TITAN 30/50PM	TITAN 30/50P														49.7	43.8
TITAN 15/70PM	TITAN 15/70P	3"	Ø 70 mm		150	70	585	95	300		405	256	150	92	53.0	50.7
TITAN 20/70PM	TITAN 20/70P														54.9	53.0
TITAN 30/70PM	TITAN 30/70P														61.1	55.2